

IMB0065

COOLING SYSTEM

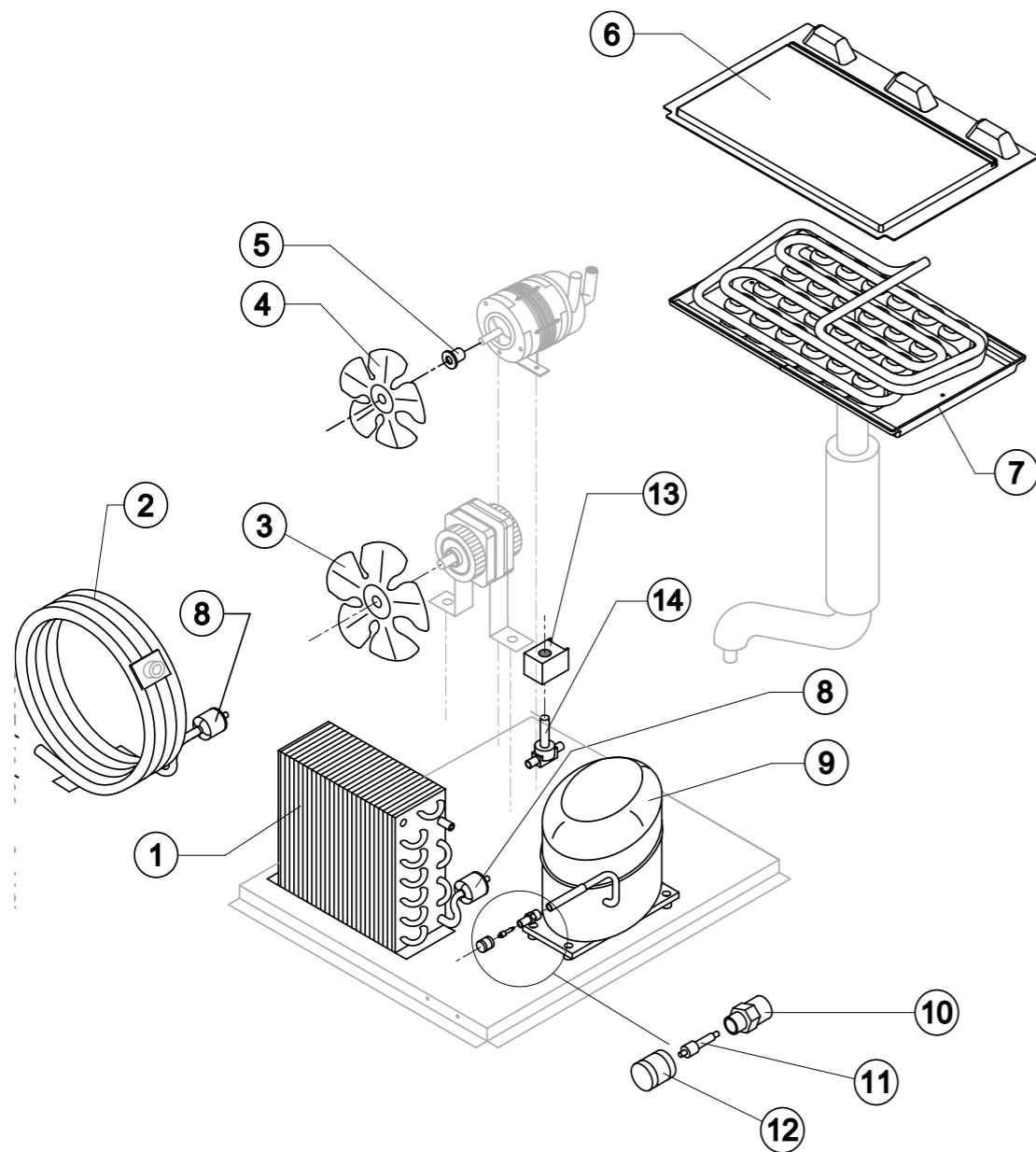

STOCK CODE	DESCRIPTION	MAN.PART NUMBER	DRAWING REF
XIMB3657	ICE MAKER BREMA- SUCTION FAN (ALL)	10213	4
XIMB3658	ICE MAKER BREMA- HUB FOR FAN (ALL)	10014	5
XIMB3505	ICE MAKER BREMA-(IMB0046/CB425/IMB0065/CB640)COMPRESSOR	23505A	9
XIMB3091	ICE MAKER BREMA - (VM ALL)HOT GAS COIL	23091	13

IMB0065

HYDRAULIC SYSTEM

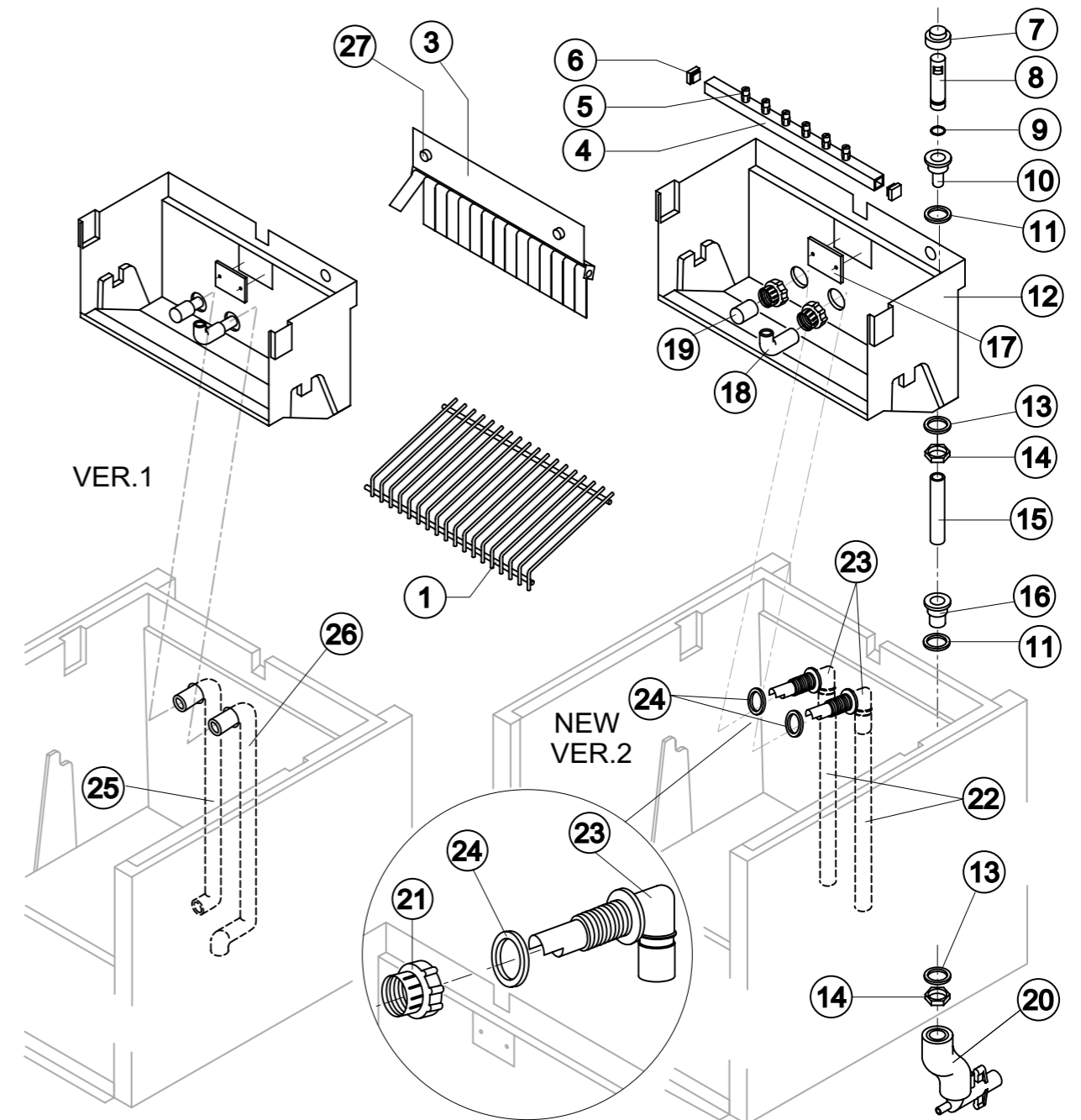

STOCK CODE	DESCRIPTION	MAN.PART NUMBER	DRAWING REF
XIMB3653	ICE MAKER BREMA-ICE CUBE SLIDE(IMB0090)	D12017	1
XIMB0002	ICE MAKER BREMA -(CB)(VM350/500) SPRAYER NOZZLES	D20002	5
XIMB0305	ICE MAKER BREMA -(CB)(ALL) -OVERFLOW CAP	10305	7
XIMB0133	ICE MAKER BREMA -(CB)(ALL) OVERFLOW PIPE	10133	8
XIMB0233	ICE MAKER BREMA -(CB)(ALL) O' RING	20233	9
XIMB0471	ICE MAKER BREMA (CB)OVERFLOW PIPE NIPPLE	10471	10
XIMB3006	ICE MAKER BREMA (CB)(ALL)SILICONE GASKET	13006	11
XIMB2005	ICE MAKER BREMA - (VM) (ALL) SUCTION FILTER	20005	19
XIMB0009	ICE MAKER BREMA-(ALL) SCREW FOR SPRAYER	20009	27

WIRING DIAGRAM

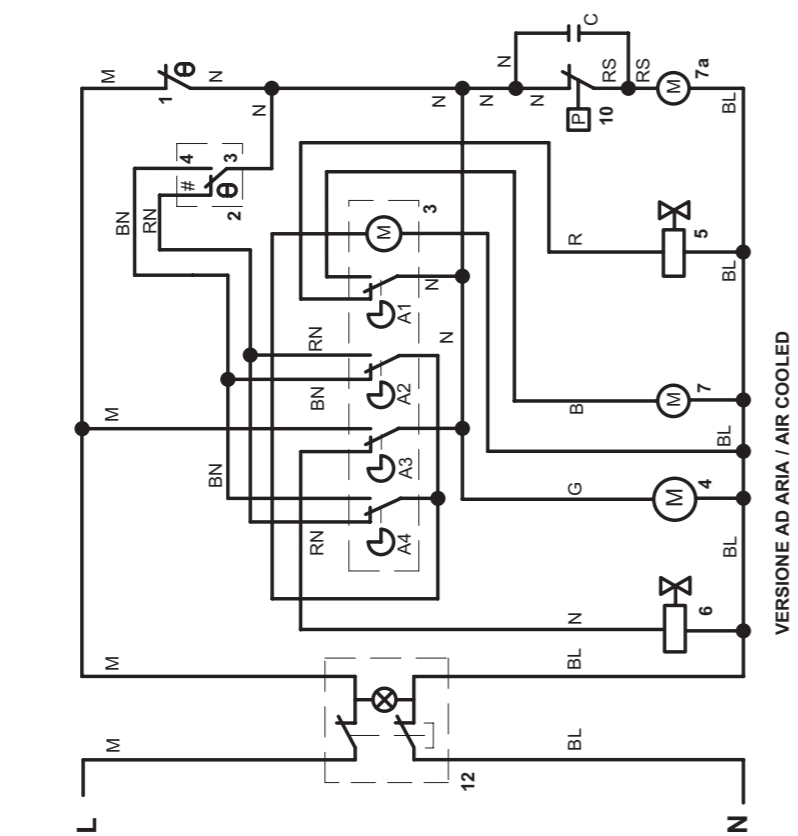
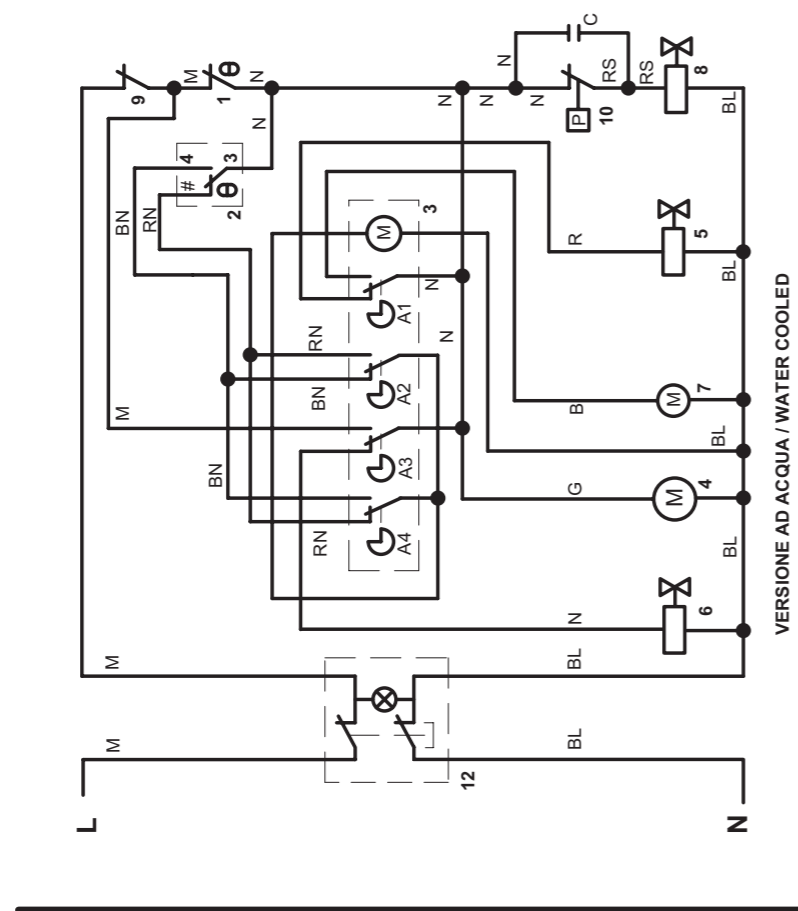

ELECTRICAL PARTS

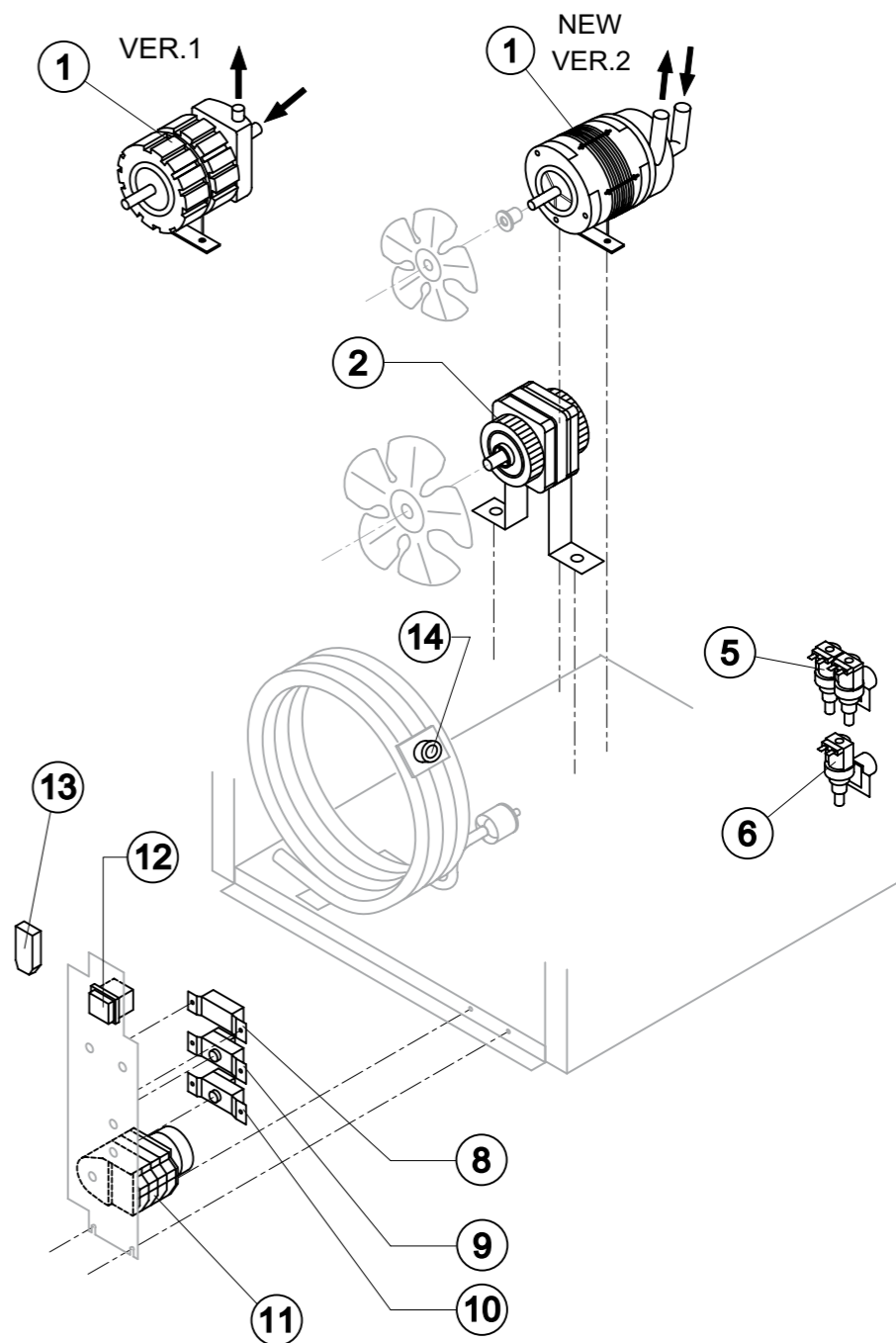

STOCK CODE	DESCRIPTION	MAN.PART NUMBER	DRAWING REF
XIMB3377	ICE MAKER BREMA-(CB249/316/425/640/955) PUMP	C23377	1
XIMB3222	ICE MAKER BREMA - (CB)(ALL) TIMER 12 MIN	23222	11
XIMB3001	ICE MAKER BREMA -(CB249/425/CB640/CB955) WATERVALVE	23001	6
XIMB3647	ICE MAKER BREMA-PRESURE SWITCH (IMB0155)	23175	8
XIMB3005	ICE MAKER BREMA-(CB)(VM350/900)BIN THERM	R23005	9
XIMB3591	ICE MAKER BREMA-(CB)(ALL) EVAP. THERMO	R23591	10
XIMB3651	ICE MAKER BREMA-SAFETY THERMOS.(IMB0028)	C23114	14