

04 processing

VPR0050

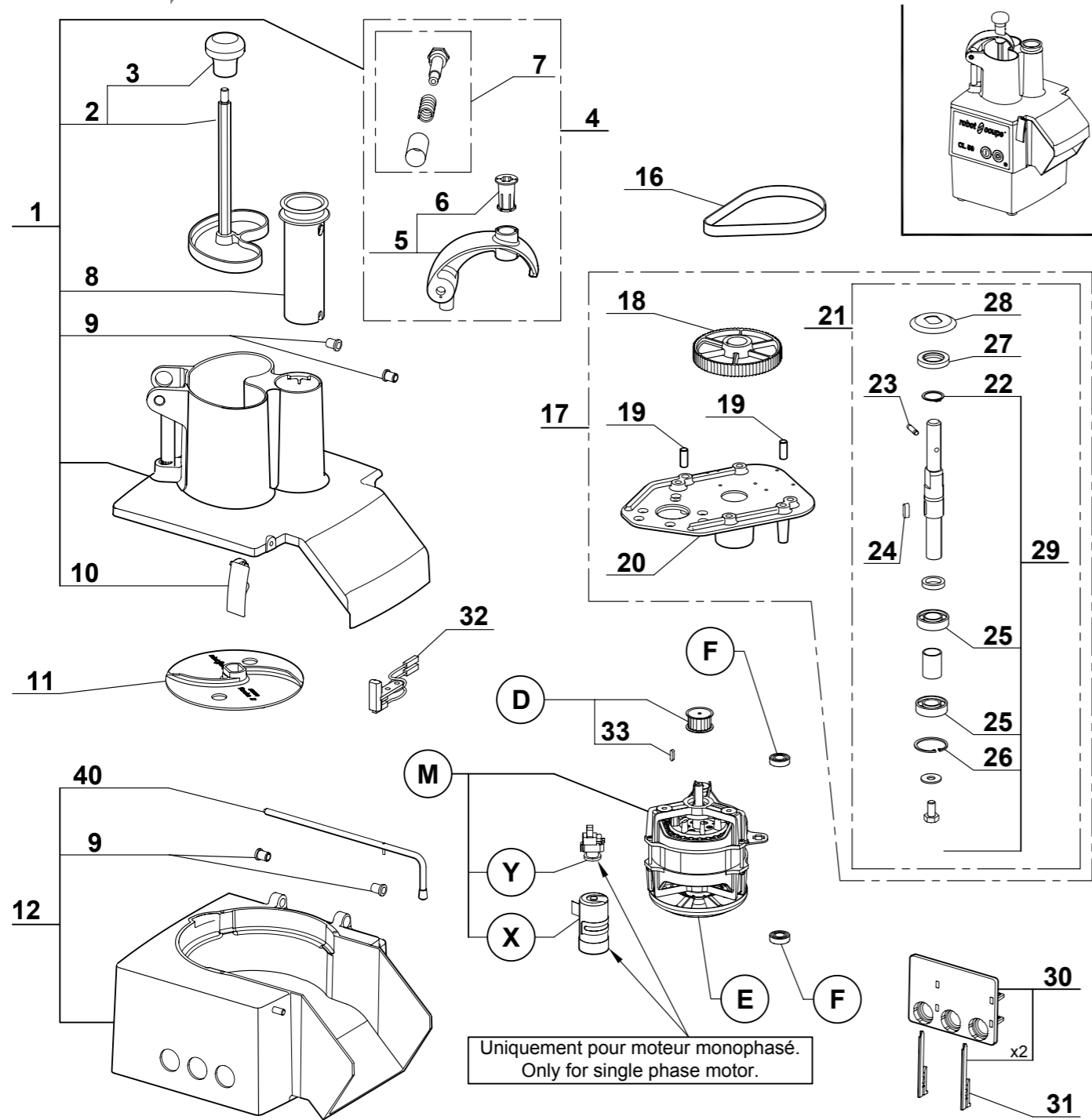

Uniquement pour moteur monophasé.
Only for single phase motor.

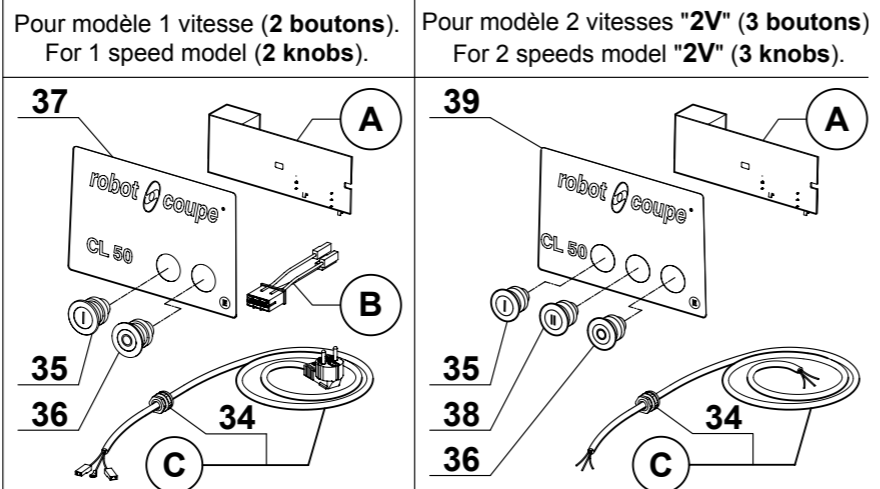
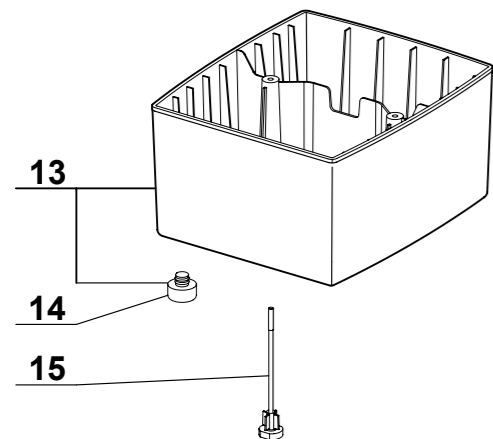

VPR0050

STOCK CODE	DESCRIPTION	MAN.PART NUMBER	DRAWING REF
XVPR0001	VEG PREP CL 50 E - PUSHER ASSEMBLY AFS	39701	2
BO0038	R/COUPE - PUSHER GUIDE ASSY [CL50E]	39703	5
XVPR0061	ROBO COUPE-CL50 PUSHER GUIDE RING	100638	6
XVPR0002	VEG PREP CL 50 E - ROUND PUSHER	118324	8
XVPR0005	VEG PREP CL50 E - SHOULDERED RINGS (X2)	39705	9
XVPR0006	VEG PREP CL50 E - SLING PLATE	102690	11
XVPR0052	VEG PREP CL50 COVER BASE	39717	13
XVPR0007	VEG PREP CL50 E - BELT 450-5MX15	507341	16
XVPR0008	VEG PREP CL50 E - TRANSMISSION SHAFT ASSEMBLY	39708	21
XVPR0009	VEG PREP CL50 E - C-RING (25)	203068	22
XFPR0018	FOOD PROCESSOR R502 - MOTOR SHAFT PIN	110 308	23
XVPR0010	VEG PREP CL50 E - BALL BEARING 6004 2RS	510217	25
XVPR0011	VEG PREP CL50 E - C-RING (42)	203206	26
XVPR0012	VEG PREP CL50 E - SHAFT SEAL 25X42X7	501678	27
XVPR0013	VEG PREP CL50 E - BALL BEARING ASSEMBLY	39709	29
XVPR0060	ROBO COUPE-CL50 PCB SUPPORT ASSEMBLY	29533	30
XBCR0077	BOWL CUTTER(R 4 V.V.) PCB LOCKING KEY	117703	31
XVPR0014	VEG PREP CL50 E - SAFETY SWITCH ASSEMBLY	29451	32
XVPR0003	VEG PREP CL 50 E - FLAT GREEN KNOB	502170	35
XVPR0004	VEG PREP CL 50 E - FLAT RED KNOB	502169	36
XVPR0025	VEG PREP CL60 D - GREEN KNOB SPEED 2	503268	38
XVPR0015	VEG PREP CL50 E - HINGE PIN	100703	40
XVPR0016	VEG PREP CL50 E - CONTROL BOARD	102481	A
XVPR0017	VEG PREP CL50 E - DRIVING PULLEY ASSEMBLY	29530	D
XVPR0018	VEG PREP CL50 E - FAN	118512	E
XVPR0044	VEG PREP CL20 D - LOWER BALL BEARING 6201 2RS	600457	F
XVPR0019	VEG PREP CL50 E - MOTOR	3114	M
XVPR0020	VEG PREP CL50 E - STARTING CAPACITOR	600018	X
XVPR0021	VEG PREP CL50 E - MOTOR STARTING RELAY	500289	Y