

PMF1030

PMF1030

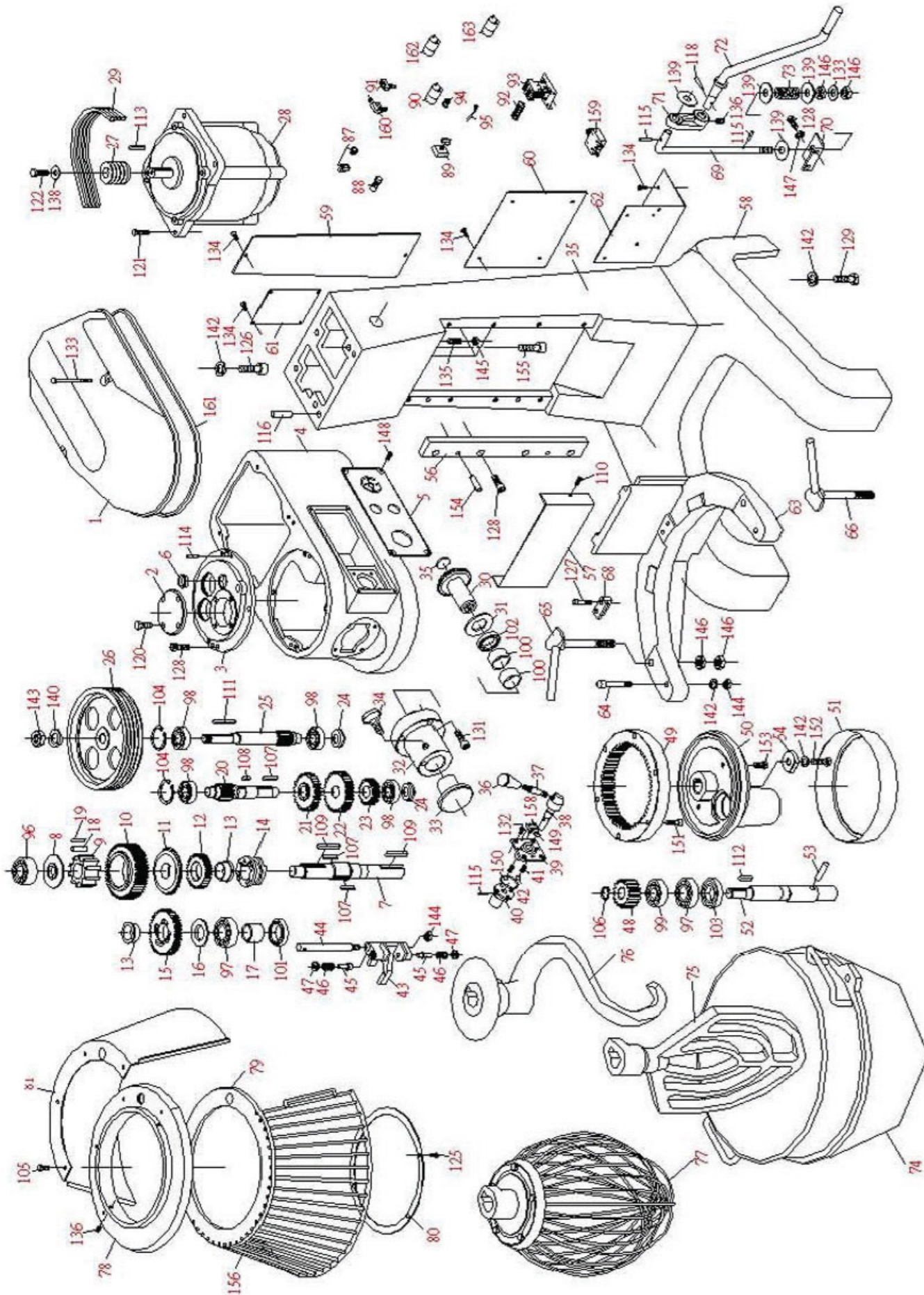

BCE CODE	DESCRIPTION	MAN.CATALOGUE NUMBER	DRAWING REF
XPMF8050	P/MIXER-30LT-COMPLETE MOTOR (ANKOR)	Z-BM30-028	28
XPMF8019	P/MIXER-30LT-DRIVE BELT (ANKOR)	Z-BM30-029	29
XPMF8006	P/MIXER-30LT-BOWL (ANKOR) (PMF1030)	Z-BM30-074	74
XPMF8015	P/MIXER-30LT-FLAT BEATER (ANKOR)	Z-BM30-075	75
XPMF8011	P/MIXER-30LT-DOUGH HOOK C-TYPE (ANKOR)	Z-BM30-076	76
XPMF8093	P/MIXER - WHISK [PMF1030]	Z-BM30-077	77
XPMF8031	P/MIXER-30/40LT-OFF SWITCH RED (ANKOR)	Z-BM30-087	87
XPMF8030	P/MIXER-30/40LT-ON SWITCH GREEN (ANKOR)	Z-BM30-088A	88
XPMF8026	P/MIXER-30LT-CAPACITOR (ANKOR)	Z-BM30-090	90