

CONTROL PANEL PARTS

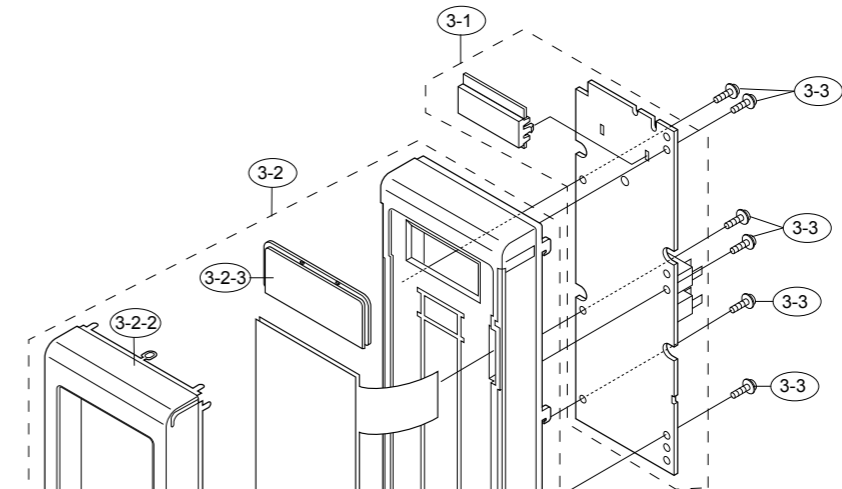

DOOR PARTS

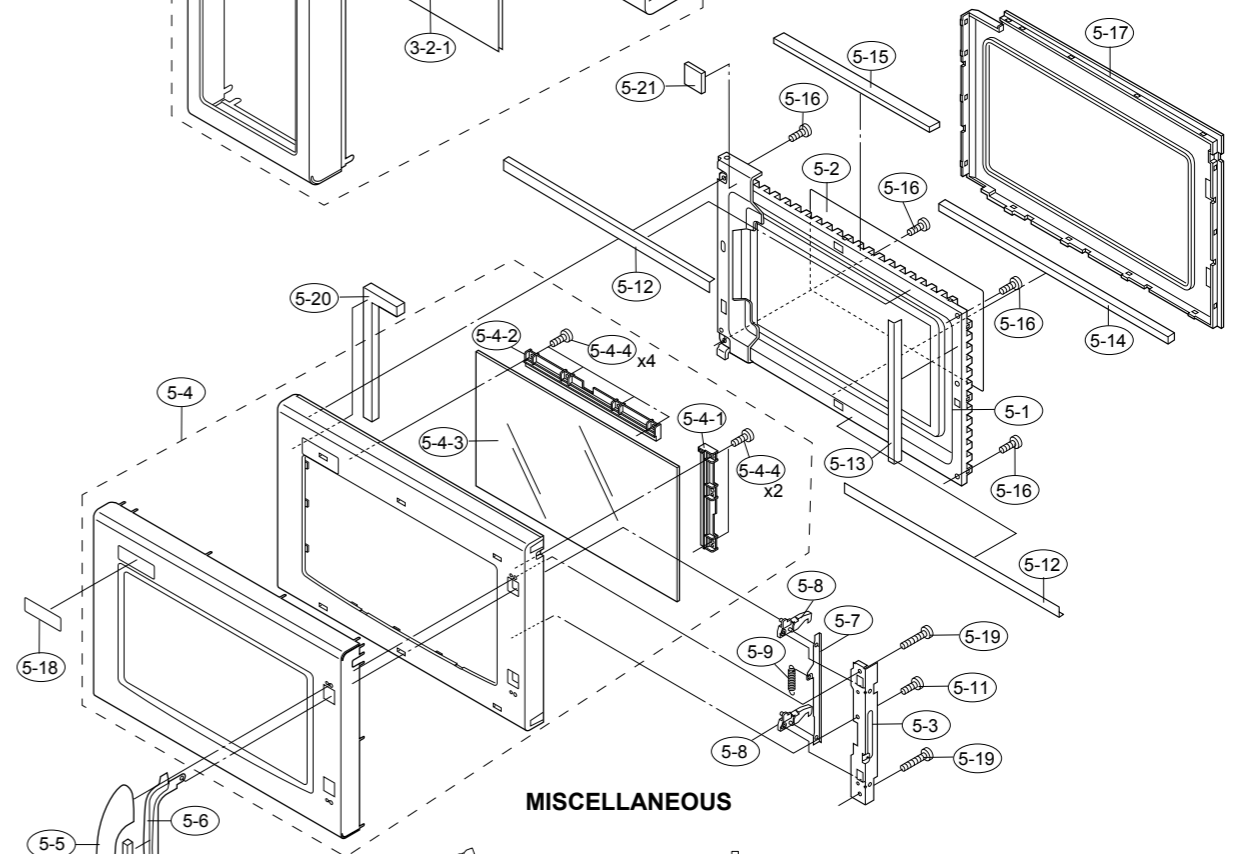

MISCELLANEOUS

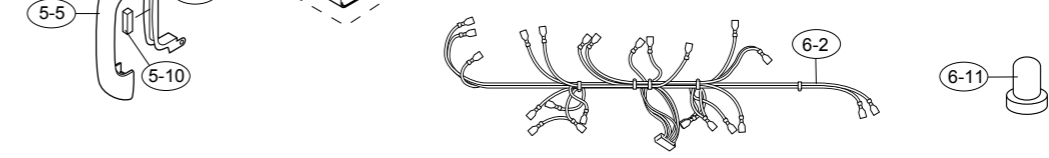

Actual wire harness may be different from illustration.

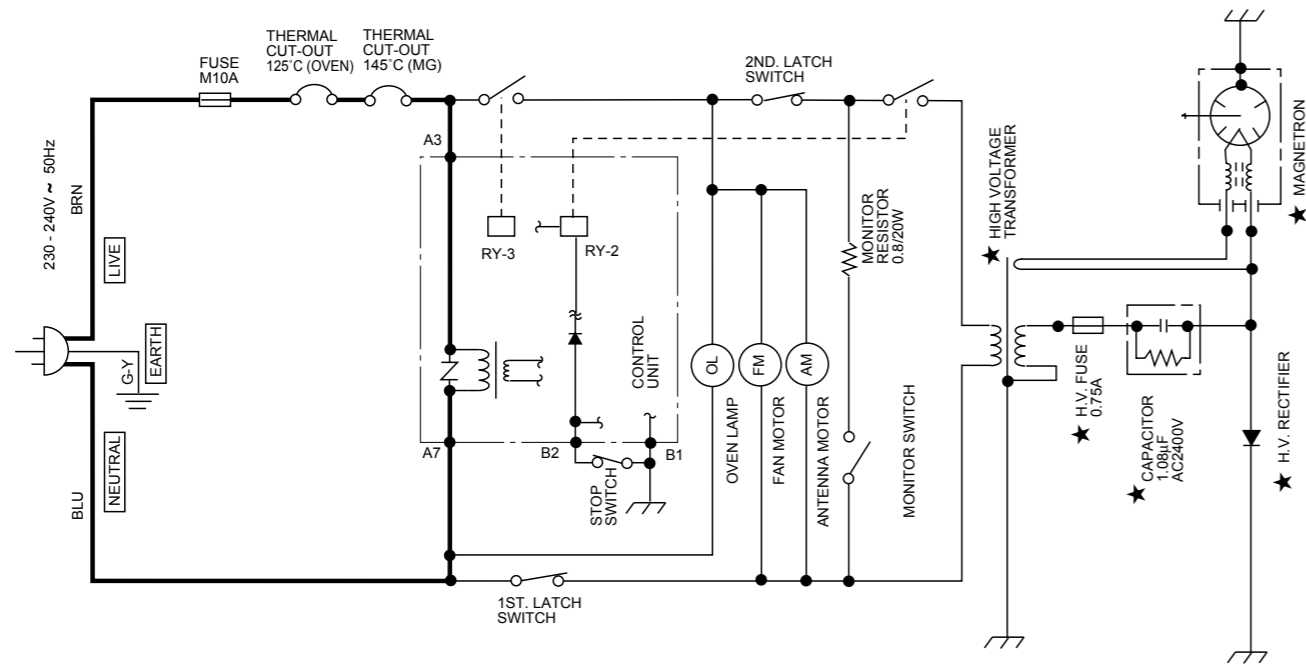
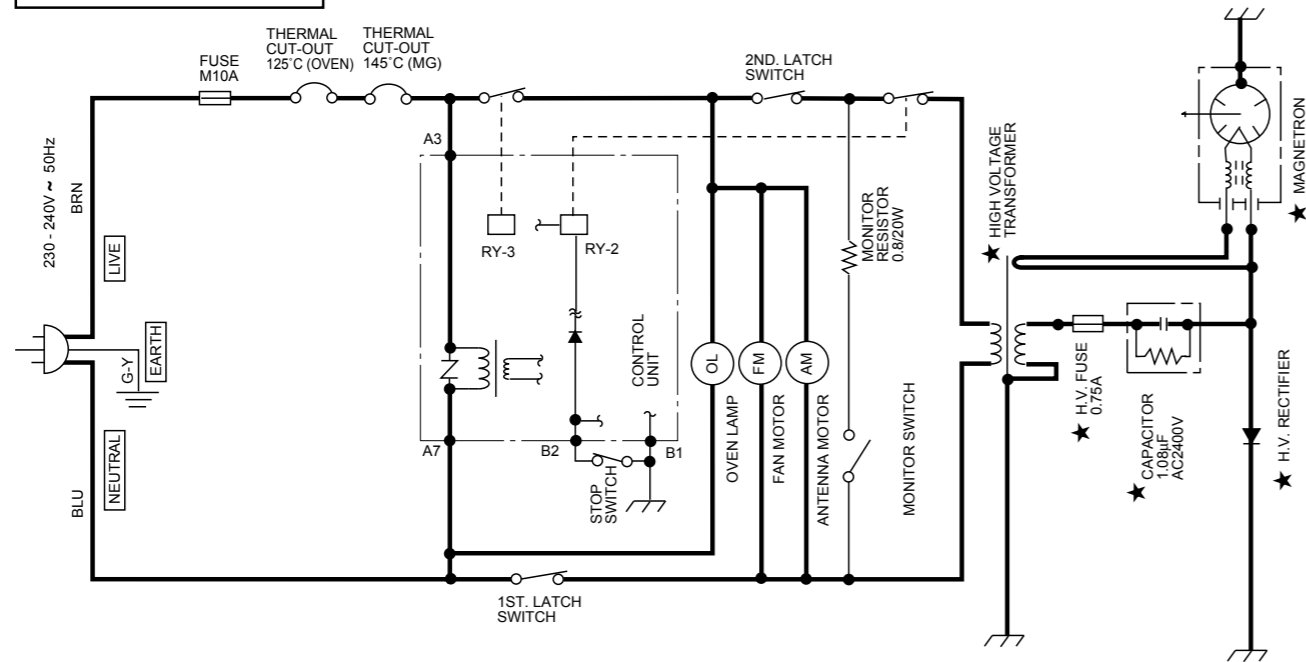

Figure O-1 Oven Schematic-OFF Condition

SCHEMATIC
NOTE: CONDITION OF OVEN
1. DOOR CLOSED.
2. "SELECT TIME" PAD TOUCHED.
3. COOKING TIME ENTERED.
4. START PAD TOUCHED.



STOCK CODE	DESCRIPTION	MAN.PART NUMBER	DRAWING REF
XMWS2001	MICROWAVE OVEN SHARP - ANTENNA MOTOR	RMOTDA234WRE0	1-11
XMWS1002	MICROWAVE OVEN SHARP - MAGNETRON	SMAG02	1-15
XMWS0555	MICROWAVE OVEN SHARP - FUSE 10 AMP	QFS-CQ001YBE0	1-17
XMWS0556	MICROWAVE OVEN SHARP - FUSE 0.10 AMP HOLDER	SHVF-1	1-18
XMWS2082	MICROWAVE OVEN SHARP - POWER CORD	QACC-A082WRE0	1-4
XMWS2009	MICROWAVE OVEN SHARP-TRANSFORMER	RTRNA574WRE0	1-14
XMWS2008	MICROWAVE OVEN SHARP- HIGH VOLTAGE CAPACITOR	RCQZA245WRE0	1-6
XMWS2011	MICROWAVE OVEN SHARP-FAN MOTOR	RMOTEA378WRE0	1-7
XMWS0074	MICROWAVE OVEN SHARP- FEET	GLEGA074WRE0	2-4
XMWS6204	MICROWAVE OVEN SHARP-PLASTIC LEG	GLEG076WRFO(2-5)	2-5
XMWS2007	MICROWAVE OVEN SHARP-CONTROL PC BOARD	CPWBFA818WRK0	3-1
XMWS2023	SHARP MICROWAVE-CONTROL PANEL CASING (3-2)	FPNLCA403WRK0	3-2
XMWS2006	MICROWAVE OVEN SHARP-TOUCH PANEL	FUNTKA899WRE0	3-2-1
XMWS2014	MICROWAVE OVEN SHARP- CERAMIC BASE PLATE	FGLSPA062WRE0	4-1
XMWS2015	MICROWAVE OVEN SHARP - CAPACITOR HOLDER	LBNDKA139WRW0	4-11
XMWS2003	MICROWAVE OVEN SHARP - STIRRER ASSEMBLY	FPLT-A007WRY0	4-14
XMWS2005	MICROWAVE OVEN SHARP-STIRRER MICA WASHER	XBPWW40P04000	4-17
XMWS2002	MICROWAVE OVEN SHARP - ANTENNA MOTOR SHAFT	NSFTPA033WRFO	4-19
XMWS2010	MICROWAVE OVEN SHARP-LATCH HOOK	PHOK-A121WRFZ	4-8
XMWS6203	MICROWAVE OVEN SHARP - D/ HANDLE LATCH SPACER	PCUSUA506WRP0	5-10
XMWS1199	MICROWAVE OVEN SHARP - CHOCK COVER	GCOVHA407WRFO	5-17
XMWS1198	MICROWAVE OVEN SHARP - SEALER FILM	PSHEPA649WRE0	5-2
XMWS2000	MICROWAVE OVEN SHARP - LATCH ANGLE ASSY	FANGKA206WRYO 5-3	5-3
XMWS2018	MICROWAVE OVEN SHARP - DOOR CASE ASSEMBLY	FCOV-A004WRK0	5-4
XMWS1196	MICROWAVE OVEN SHARP - DOOR HANDLE	GWAKPA580WRMO	5-5
XMWS6202	MICROWAVE OVEN SHARP - DOOR HANDLE LATCH MECHANISM	JHNDMA040WRW0	5-6
XMWS2017	MICROWAVE OVEN SHARP - LATCH HEAD	LSTPPA181WRFO	5-8